

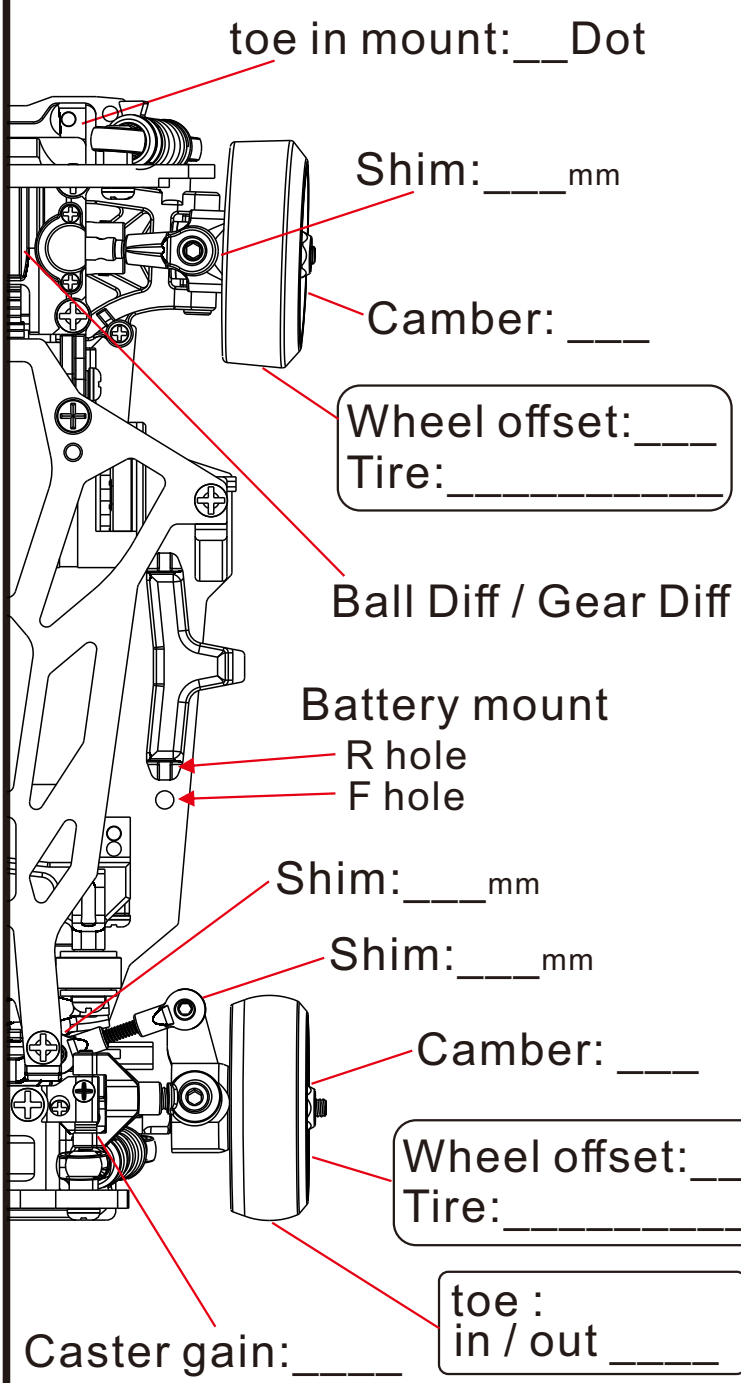

Date: _____ Place: _____
Track: _____ Driver: _____

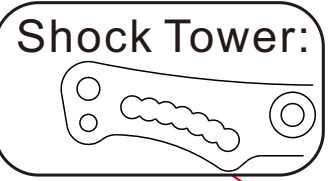

Rear



Spring: _____
Grease: _____



Down stop: _____ Height: _____

Front

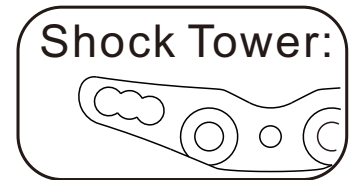

Shim: _____ mm

Spring: _____
Grease: _____

Shim: _____ mm



Down stop: _____

Height: _____ Outward: _____ mm
(Front offset)

Speed controller

Program card setup

1. Running Mode(1~3) _____
2. Low Voltage Cut-Off(1~6) _____
3. Over-heat protection(1~2) _____
4. Neutral Range(1~3) _____
5. Start Mode (punch)(1~9) _____
6. Max. Forward Force(1~5) _____
7. Max. Reverse Force(1~4) _____
8. Max. Brake Force(1~5) _____
9. Drag Brake Force (1~8) _____
10. Initial Brake Force(1~4) _____
11. Timing(1~8) _____

Body: _____ Wheel Base: _____

Motor: _____ Pinion gear: _____

Spur gear: _____ Battery: _____

Gyro gain: _____ % Note: _____

