

## Step 01

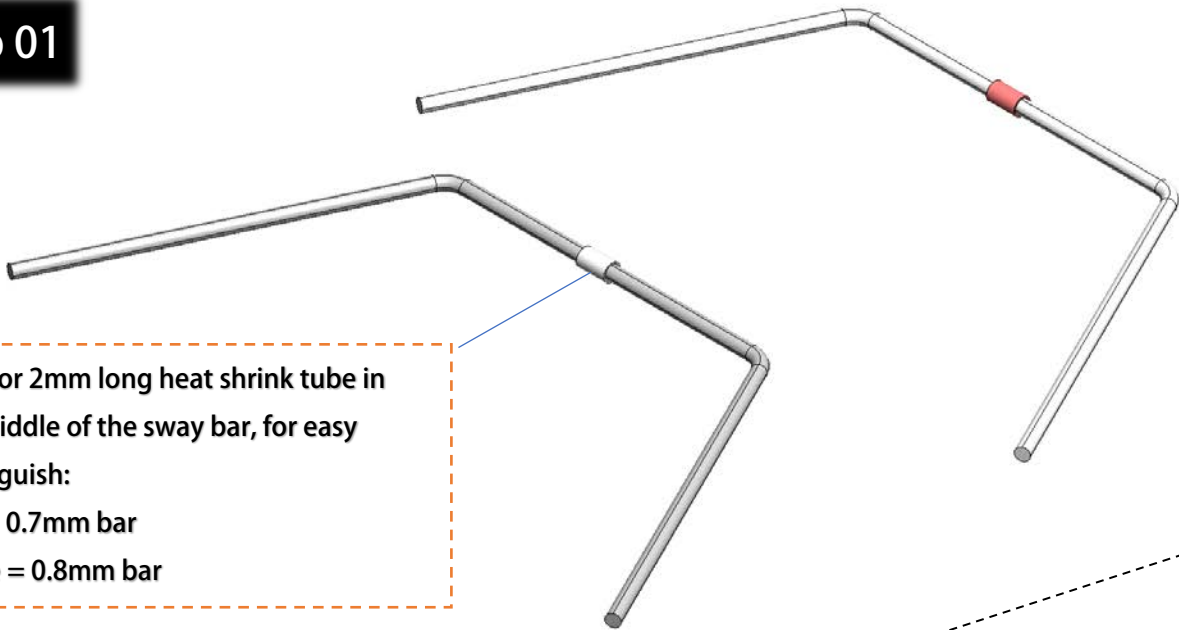

Put 1 or 2mm long heat shrink tube in the middle of the sway bar, for easy distinguish:  
Red = 0.7mm bar  
White = 0.8mm bar

## Step 02

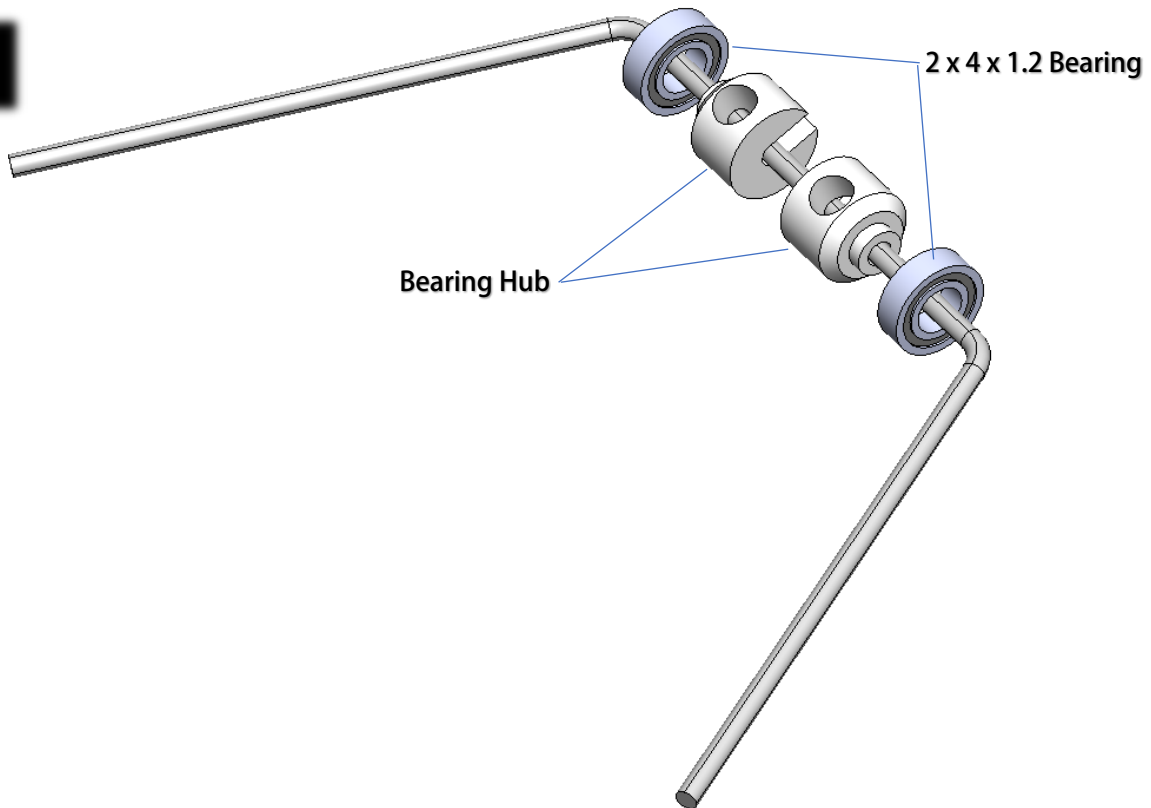

### Step 03

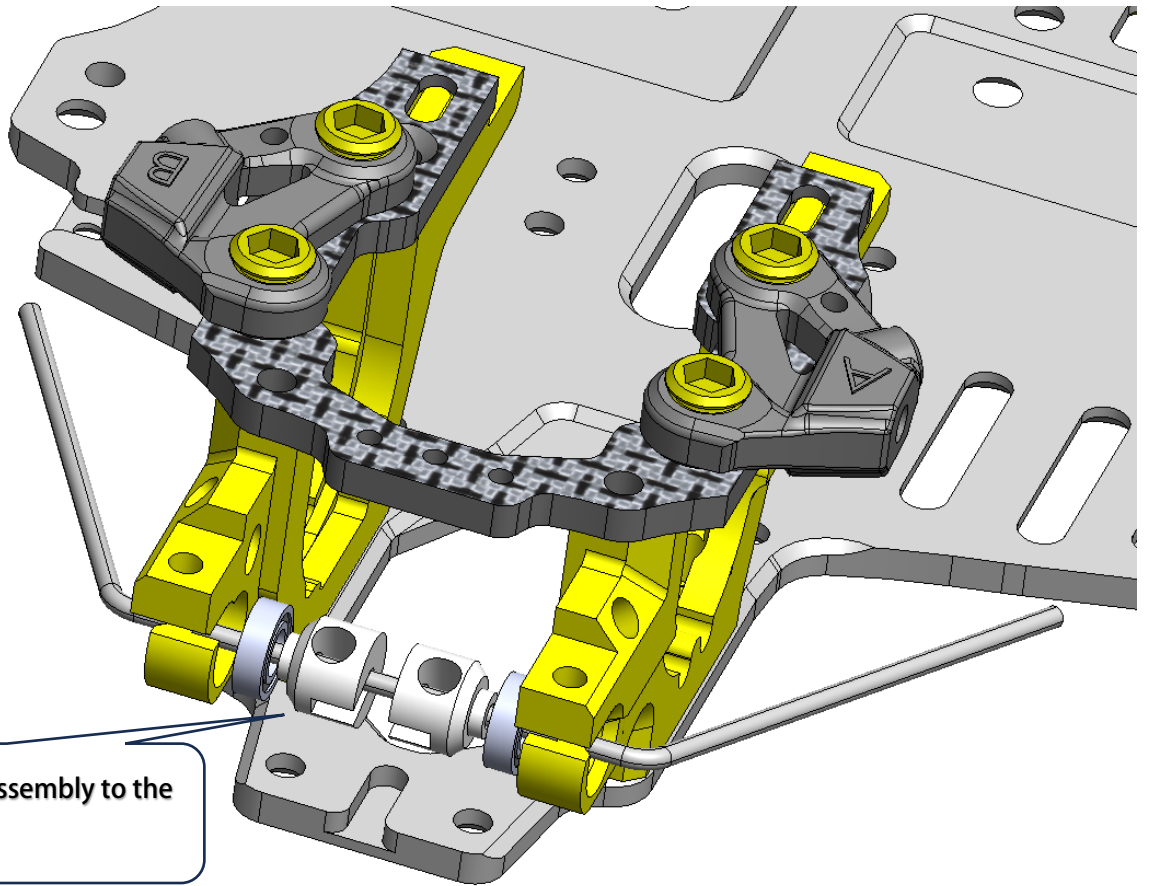

Put the sway bar assembly to the rear bulkhead slot

### Step 04

1. Align the sway to the middle of the chassis
2. Push the bearing into the bearing slot of the bulkhead.
3. Then lock the bearing hub with M2 set screw.

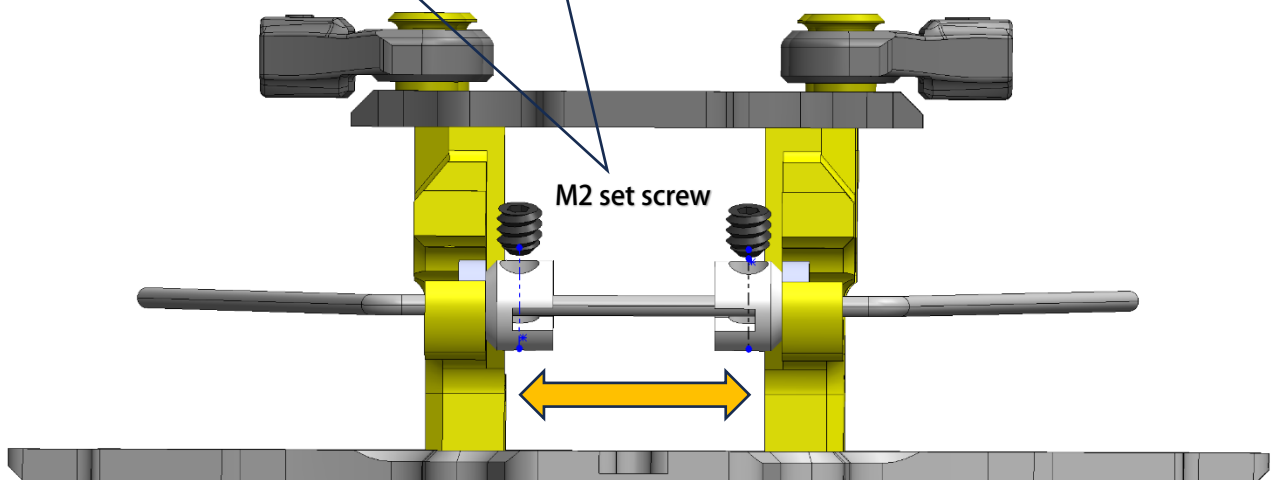

Step 05

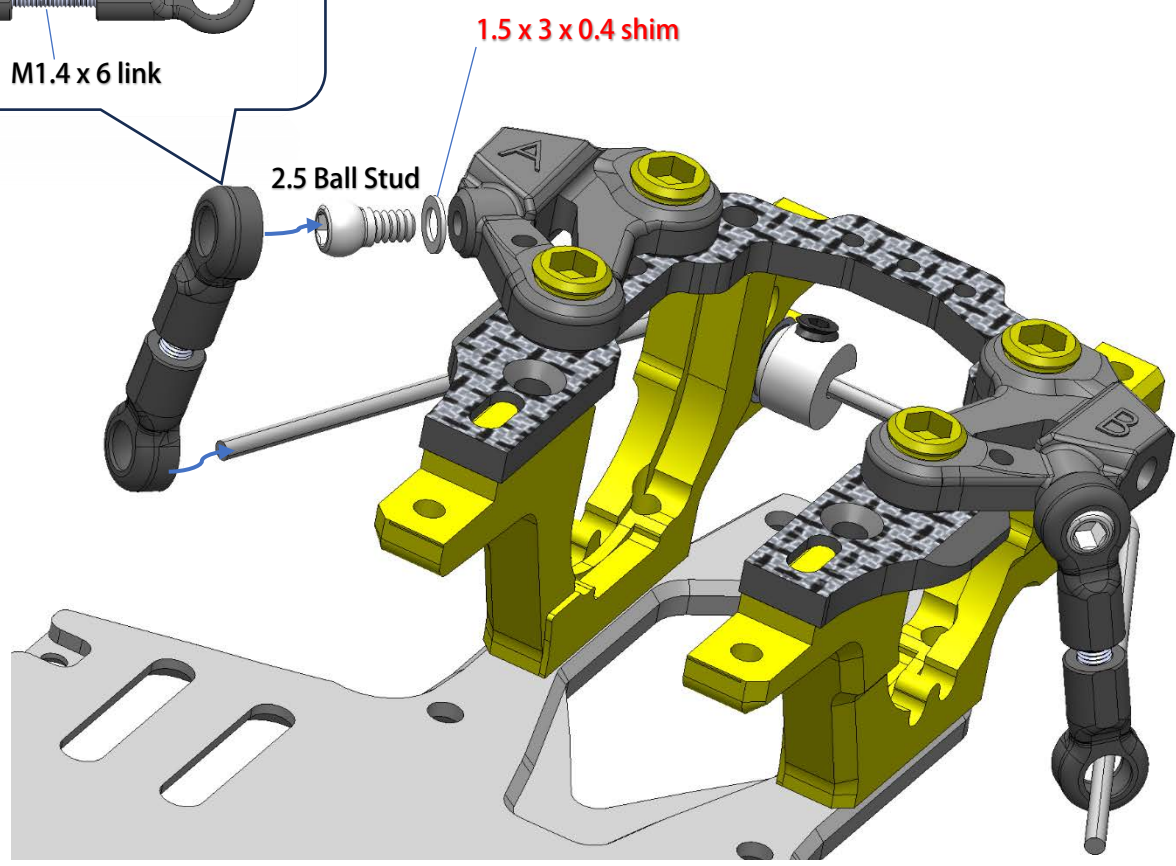
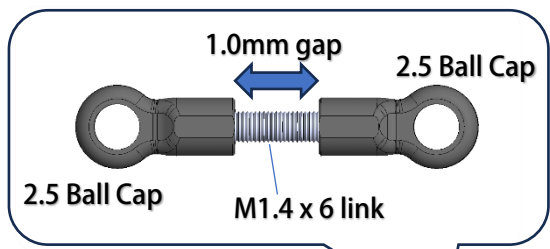

Final Step

