

Step 01

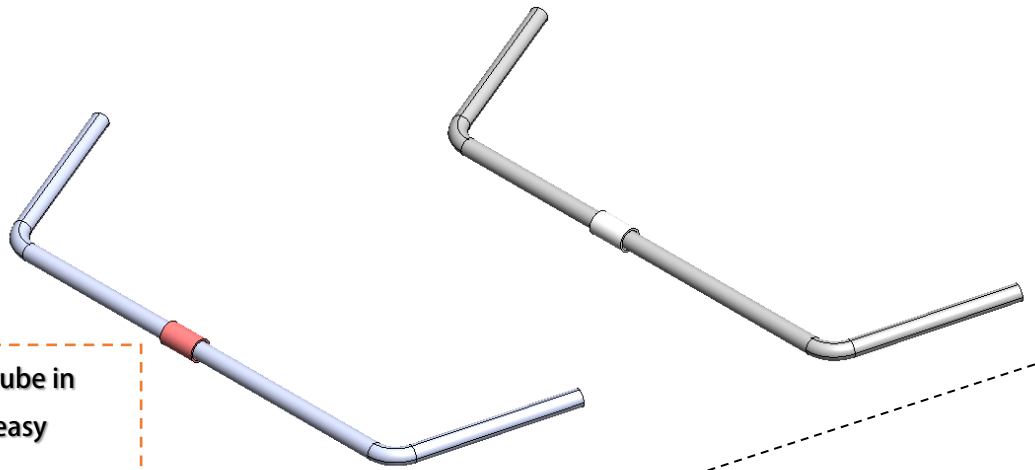

Put 1 or 2mm long heat shrink tube in the middle of the sway bar, for easy distinguish:

Red = 0.7mm bar

White = 0.8mm bar

Step 02

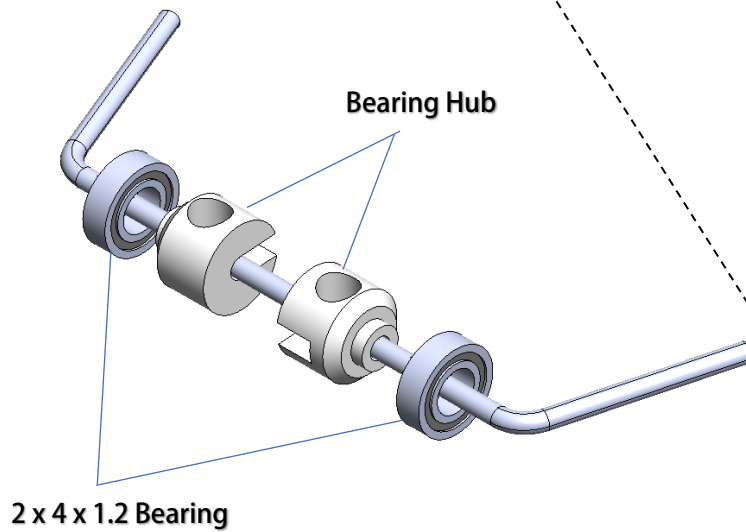

Step 03

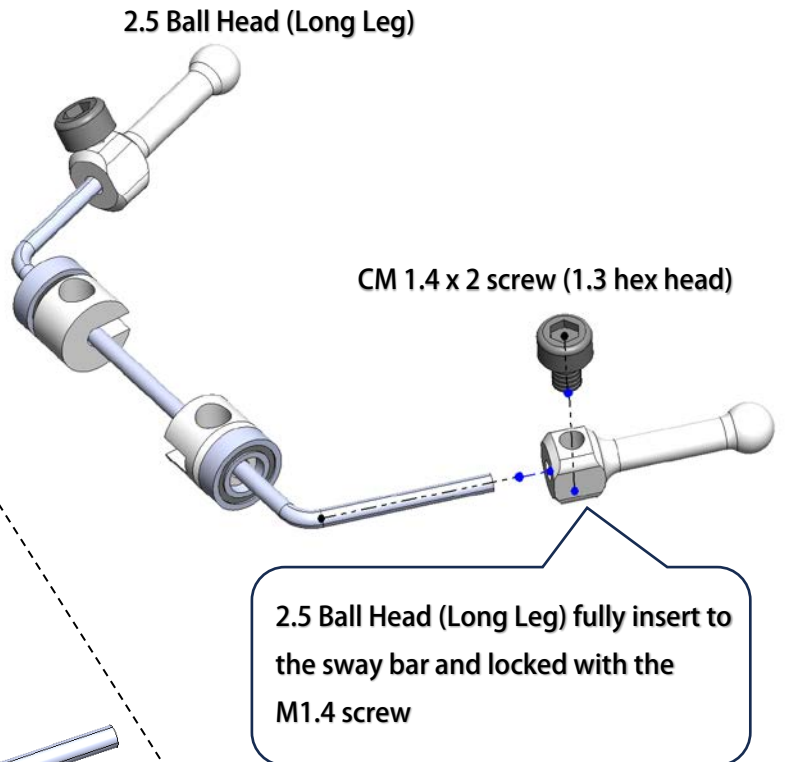

Step 04

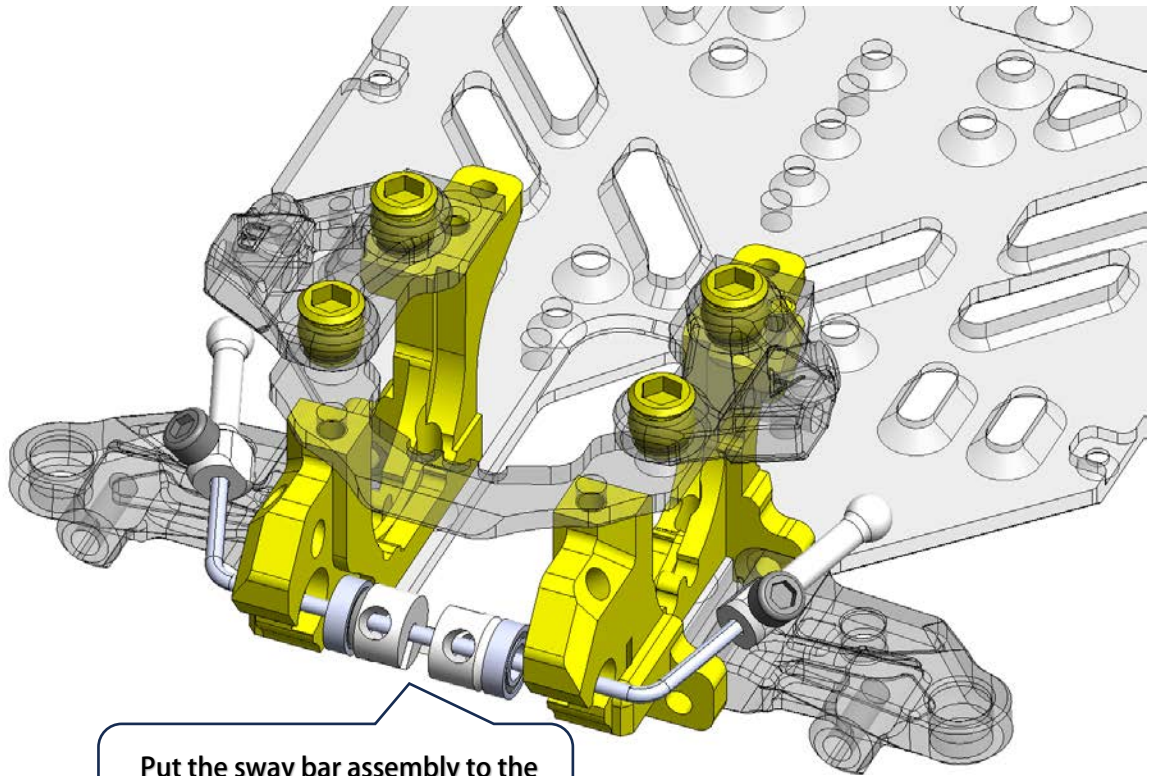

Put the sway bar assembly to the front bulkhead slot

Step 05

1. Align the sway to the middle of the chassis
2. Push the bearing into the bearing slot of the bulkhead.
3. Then lock the bearing hub with M2 set screw.

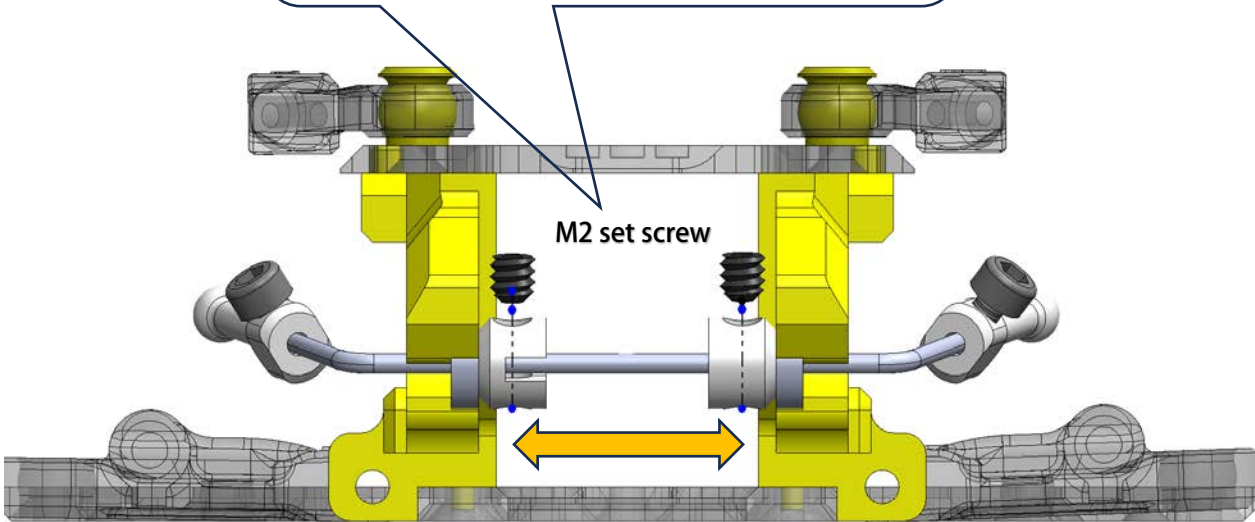

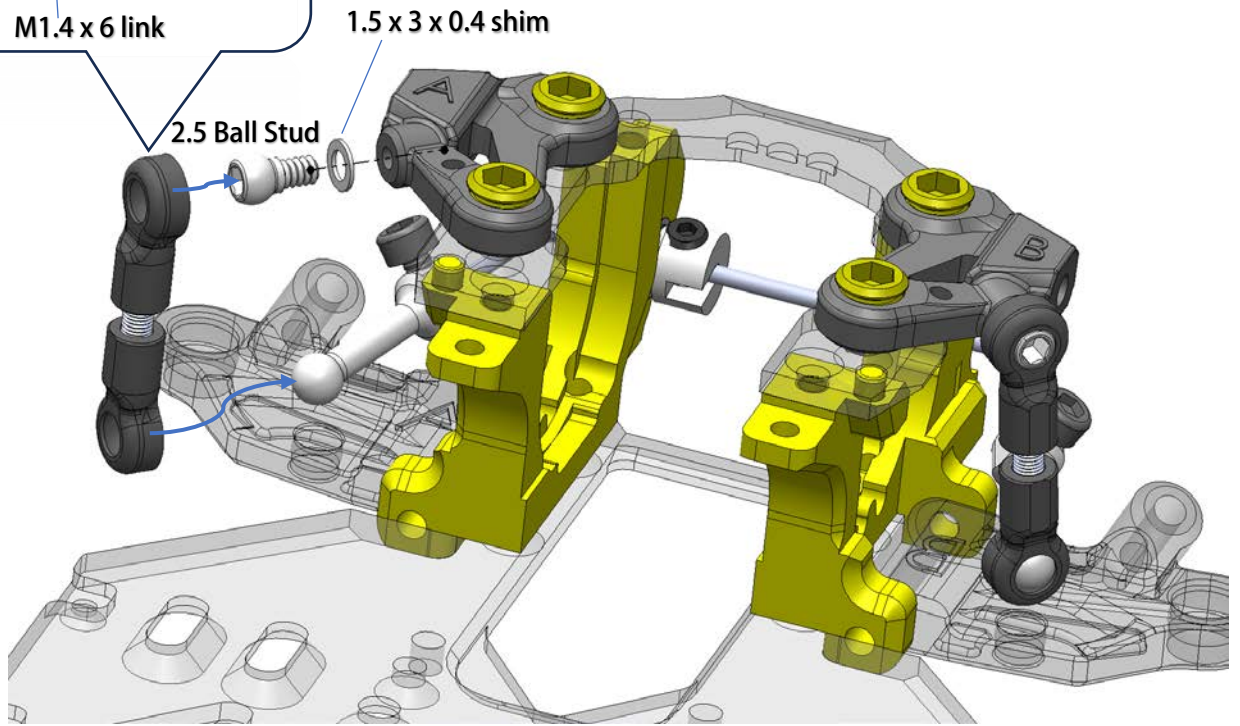
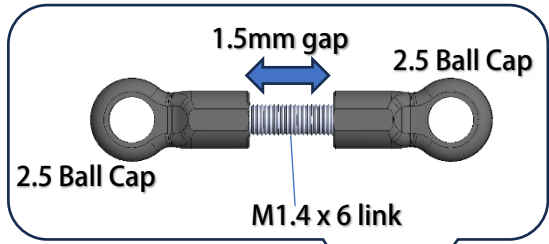

Final Step

